



# STICK BOMBS

# TABLE OF CONTENTS:

## BOMBS AND WEAVES

- The Square Weave - 5
- The X-Bomb Weave - 9
- The Compass Weave - 13
- The Cobra Weave - 17
- The Zigzag Weave - 21
- Decoy Bomb - 25

## ARTILLERY

- Slingshot - 27
- Catapult - 29
- Ballista - 35

# WHAT ARE STICK BOMBS?

Stick Bombs are wooden popsicle sticks and/or tongue depressors woven together in various configurations to build tension. Remove one stick and BOOM! You get a rupturing reaction of holy stick bomb goodness!

## TONGUE DEPRESSOR SPECS:



## POPSICLE STICK SPECS:



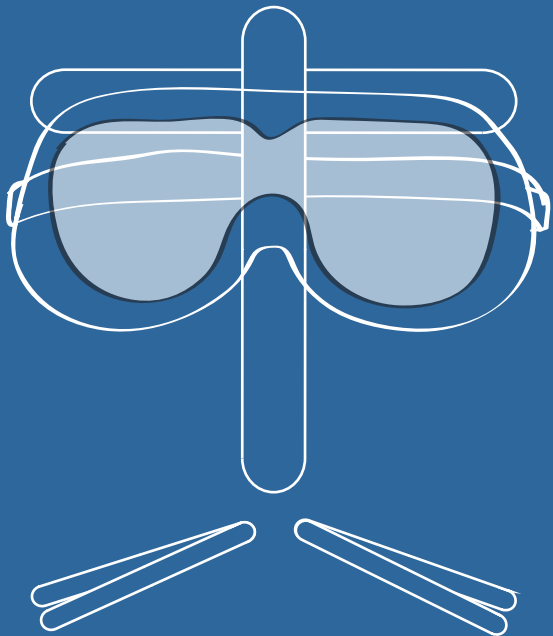

## SERGEANT STICK BOMBS SAYS:

If you're going to play with Stick Bombs, you should practice stick safety and always wear safety goggles. It might seem a little silly at first, but some stick weaves (especially if done with the smaller popsicle sticks) can pack a lot of power - so don't risk getting punched! After all, it's hard to be taken seriously when you have a popsicle stick lodged in your face.



## TWO WAYS TO DETONATE:

PULLING

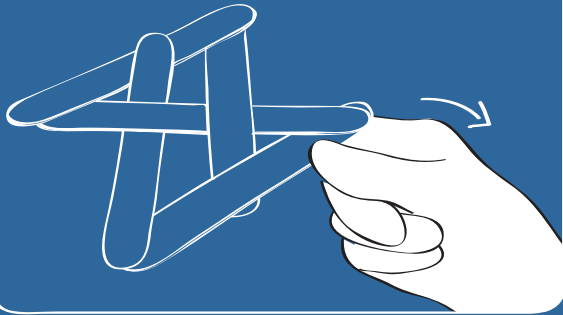

FLICKING

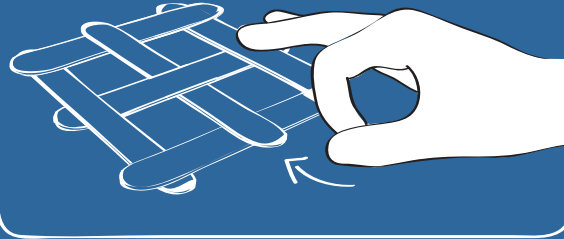

## BUILDING TIP:

### DOUBLE STICK

(Bombs can be made extra explosive by laying two sticks down on top of each other in each pattern - i.e. more sticks, less space, more tension)



# THE SQUARE

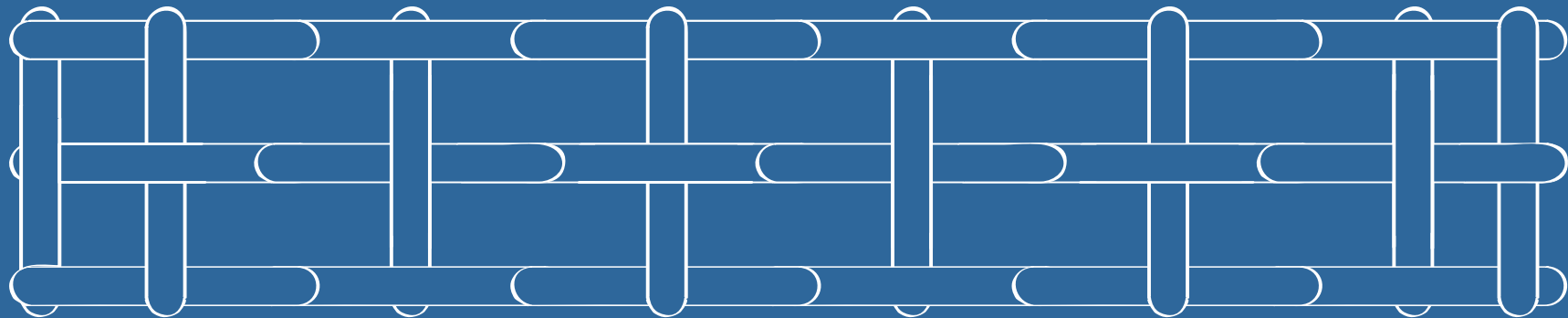

## STEP 1

PLACE 2 STICKS IN AN UPSIDE DOWN "T" CONFIGURATION.

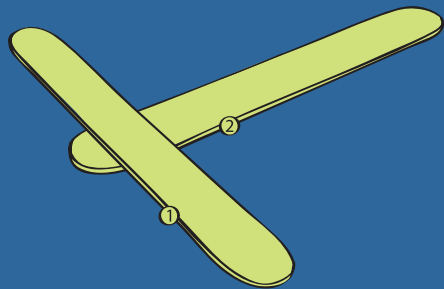

## STEP 2

PLACE TWO MORE STICKS PARALLEL TO STICK 2, COVERING EACH END OF STICK 1.

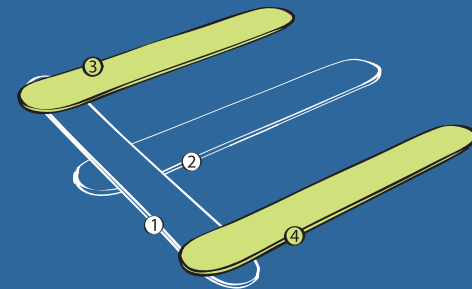

## STEP 3

WEAVE STICK 5 OVER 3, UNDER 2, AND OVER 4.

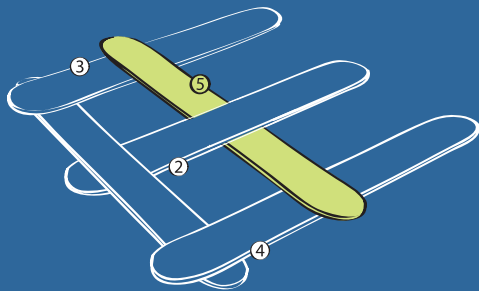

## STEP 4

LAY STICK 6 ON TOP OF 2.

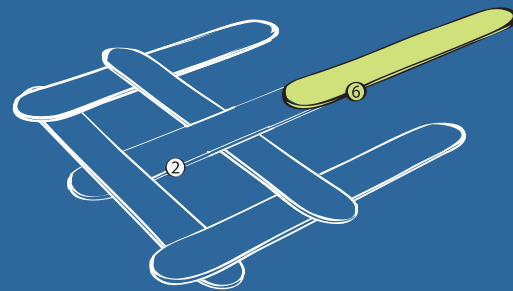

## STEP 5

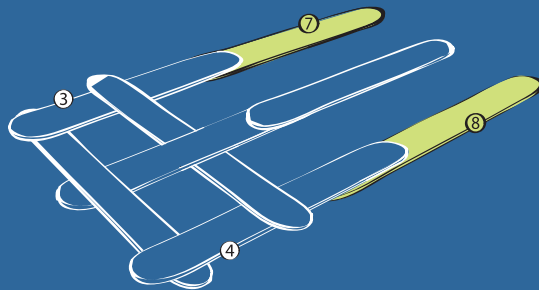

LAY STICK 7 UNDERNEATH 3  
AND STICK 8 UNDERNEATH 4.

## STEP 6

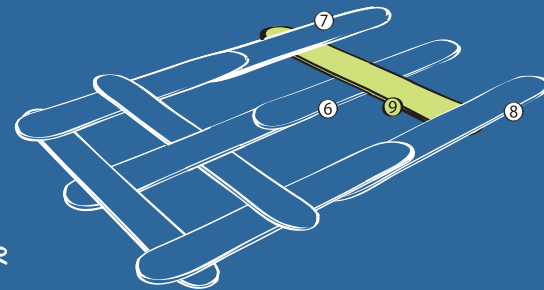

WEAVE STICK 9 UNDER 7, OVER  
6, AND UNDER 8.

## STEP 7

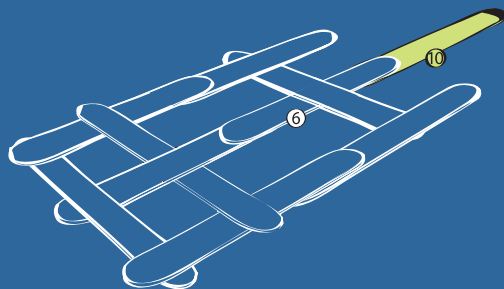

SLIDE STICK 10 UNDER 6.

## STEP 8

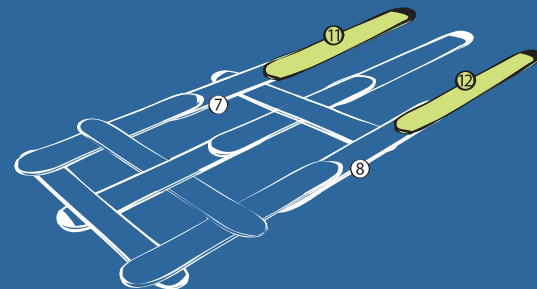

LAY STICK 11 ON TOP OF 7 AND  
STICK 12 ON TOP OF 8.  
CONTINUE BY FOLLOWING THE  
PATTERN ILLUSTRATED BELOW.

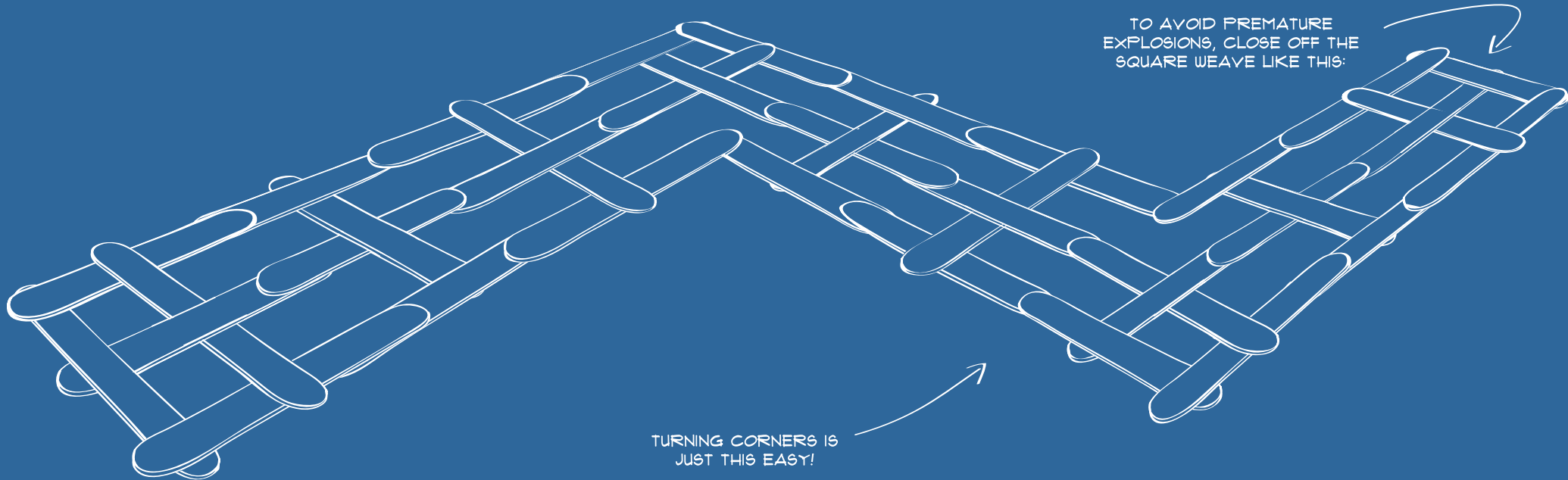

TO AVOID PREMATURE  
EXPLOSIONS, CLOSE OFF THE  
SQUARE WEAVE LIKE THIS:

TURNING CORNERS IS  
JUST THIS EASY!

# THE X-BOMB

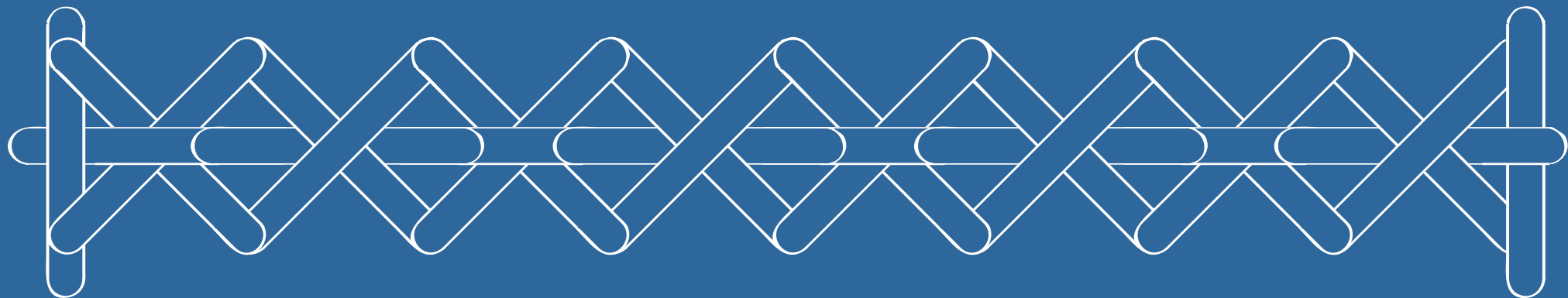

## STEP 1

PLACE THE FIRST TWO STICKS SO THAT THEY CREATE AN "X."

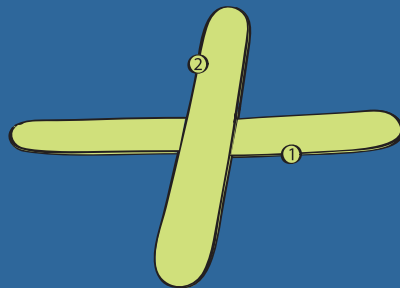

## STEP 2

PLACE STICK 3 ON TOP OF 1 AND 2.

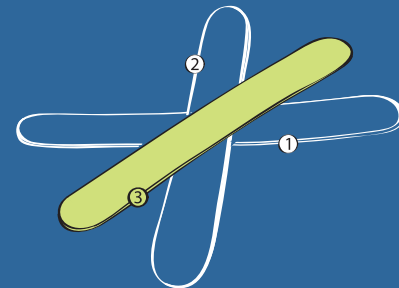

## STEP 3

SLIDE STICK 4 OVER 3, KEEPING THE ENDS OF UNDER 1 AND 2.

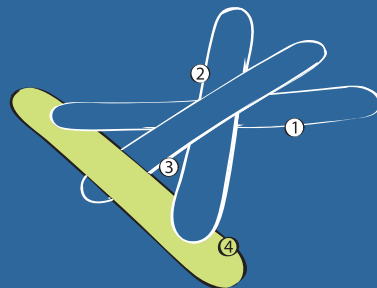

## STEP 4

POSITION STICK 5 ON TOP OF 3.

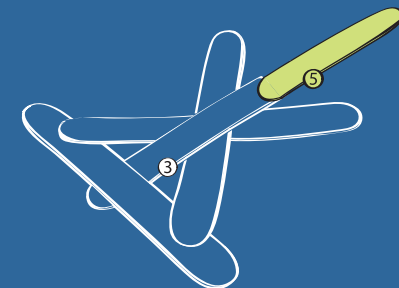

## STEP 5

LAY STICK 6 PARALLEL TO 1,  
UNDER 2, AND OVER 5.  
LAY STICK 7 PARALLEL TO 2,  
ON TOP OF 6, AND UNDER 1.

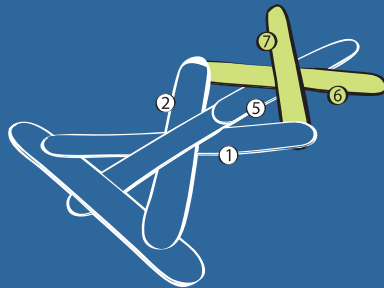

## STEP 6

SLIDE STICK 8 UNDER 5.

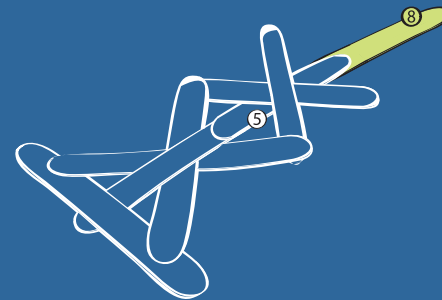

## STEP 7

PLACE STICK 9 PARALLEL TO  
6, OVER 7, AND UNDER 8.  
PLACE STICK 10 PARALLEL TO  
7, OVER 6, AND UNDER 9.

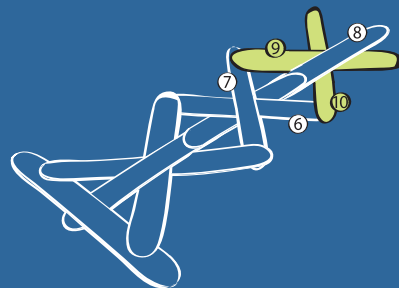

## STEP 8

LAY STICK 11 ON TOP OF 8.  
CONTINUE BY FOLLOWING THE  
PATTERN ILLUSTRATED BELOW.

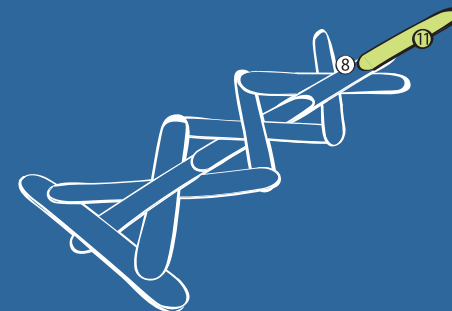



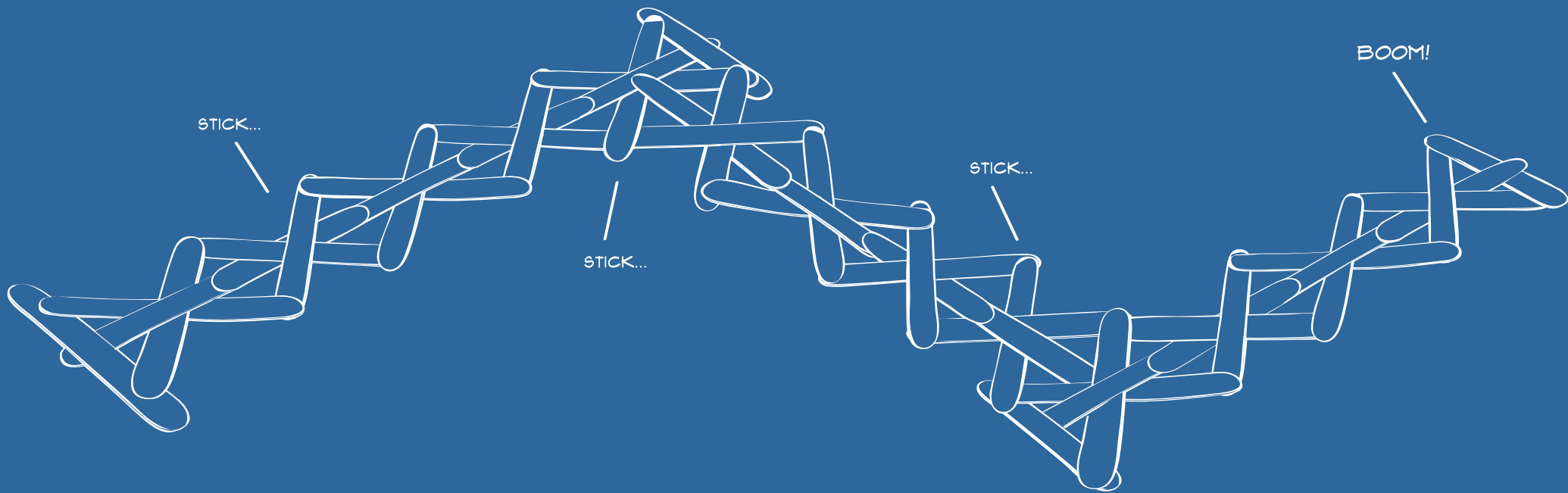

# THE COMPASS

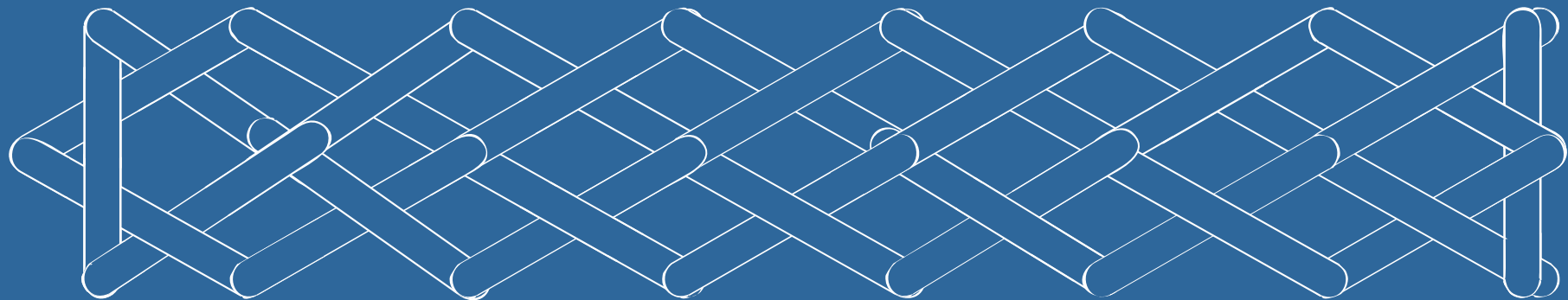

## STEP 1

LAY STICK 2 OVER STICK 1  
CREATING A "V."

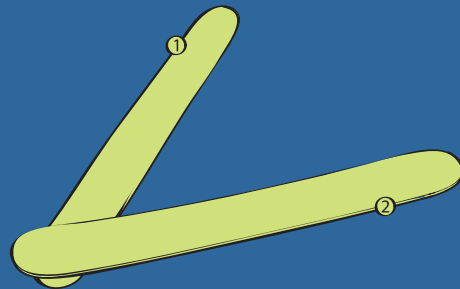

## STEP 2

LAY STICK 3 HORIZONTALLY  
OVER 2 AND UNDER 1.

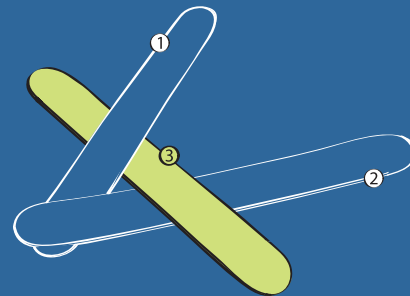

## STEP 3

LAY STICK 4 PARALLEL TO 2,  
UNDER 3, AND OVER 1.

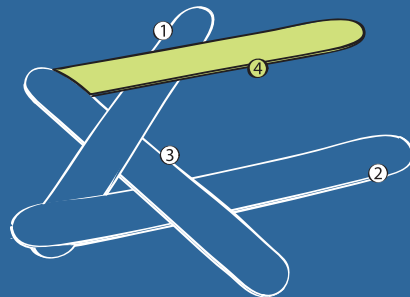

## STEP 4

LAY STICK 5 PARALLEL TO 1,  
WEAVING OVER 3, UNDER 2, AND  
OVER 4.

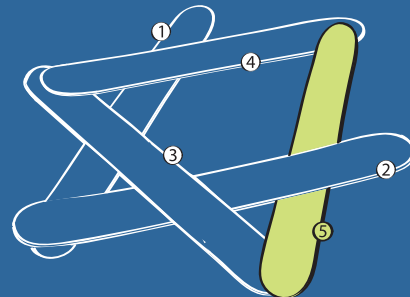

## STEP 5

LAY STICK 7 OVER 1 AND STICK 6 OVER 2 AND 7.

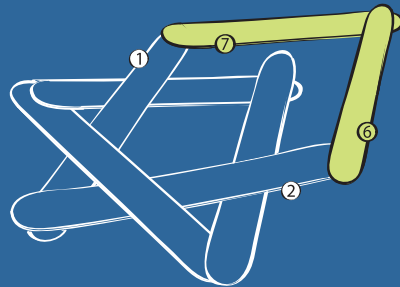

## STEP 6

SLIDE STICK 8 UNDER 7 AND IN BETWEEN STICKS 4 AND 5.

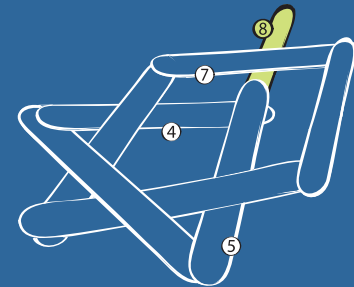

## STEP 7

WEAVE STICK 9 OVER 6, AND IN BETWEEN 5 AND 8.

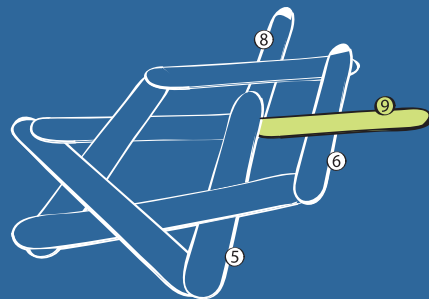

## STEP 8

LAY STICK 10 OVER 8. CONTINUE BY FOLLOWING THE PATTERN ILLUSTRATED BELOW.

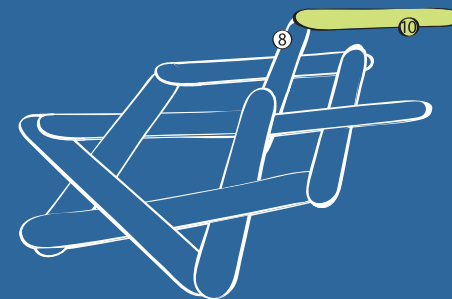

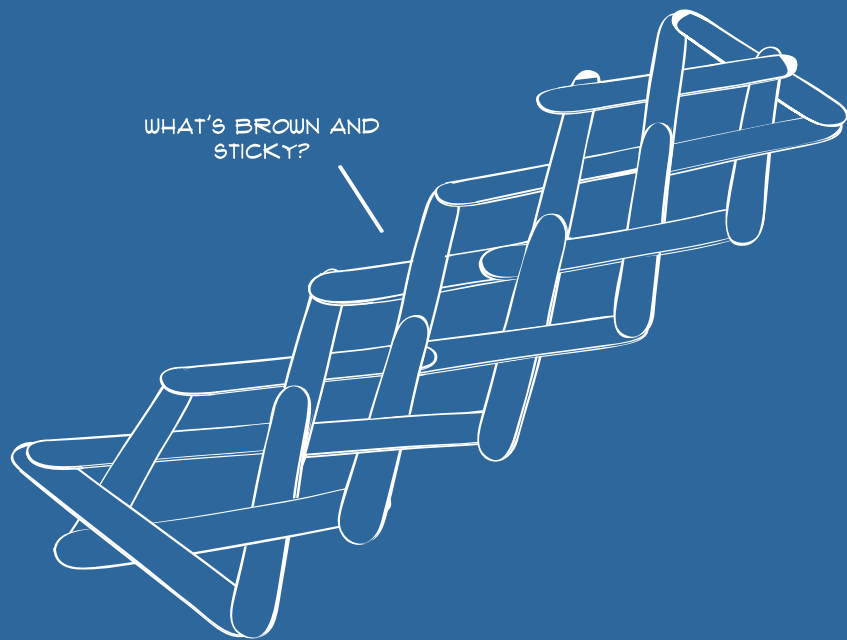

WHAT'S BROWN AND  
STICKY?

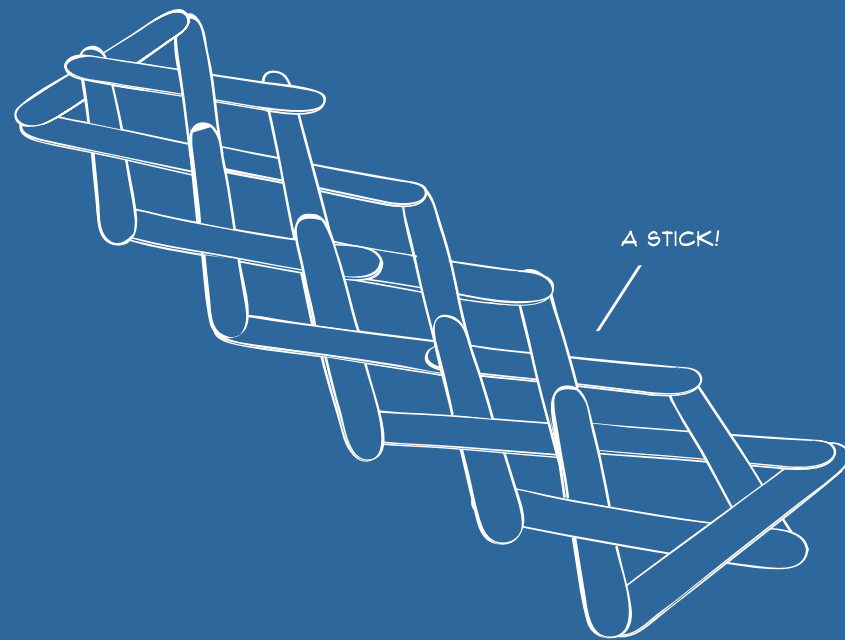

A STICK!

# THE COBRA

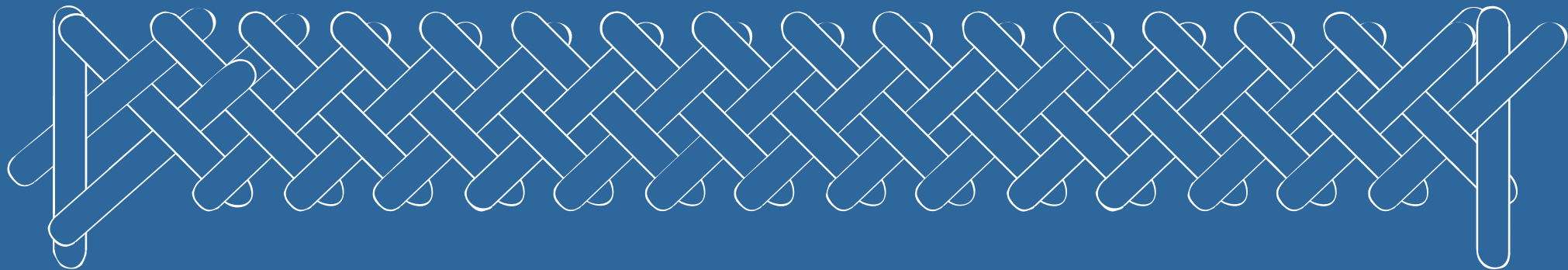

## STEP 1

LAY STICK 1 UNDERNEATH AND  
DIAGONAL FROM STICK 2.

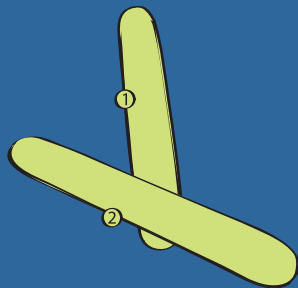

## STEP 2

LAY STICK 3 OVER THE RIGHT  
END OF 2, PARALLEL TO 1.

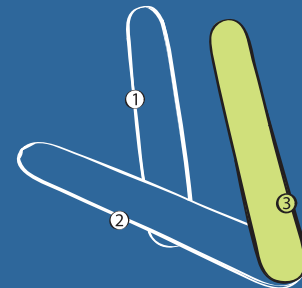

## STEP 3

WEAVE STICK 4 OVER 2,  
UNDER 1, AND OVER 3.

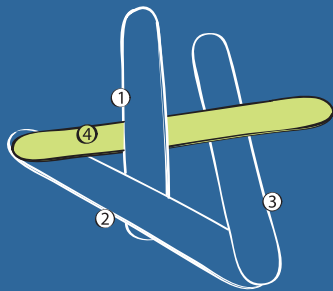

## STEP 4

LAY STICK 5 PARALLEL TO 4,  
OVER 1, AND UNDER 3.

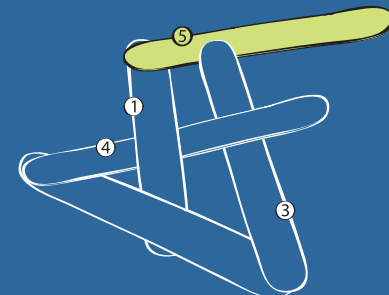

## STEP 5

LAY STICK 6 PARALLEL TO 3,  
WEAVING IT OVER 4, UNDER 5.

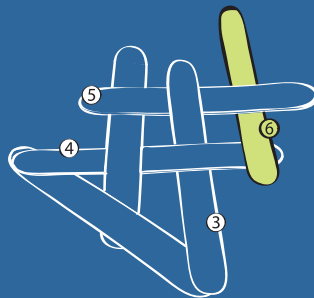

## STEP 6

LAY STICK 7 PARALLEL TO 5  
AND 4, WEAVING IT OVER 3  
AND UNDER 6.

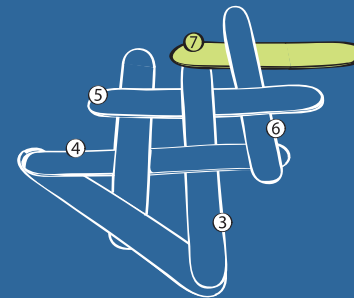

## STEP 7

LAY STICK 8 PARALLEL TO 6  
AND 3, WEAVING IT OVER 5 AND  
UNDER 7.

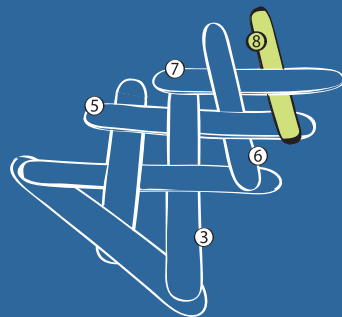

## STEP 8

LAY STICK 9 PARALLEL TO 7,  
WEAVING IT OVER 6 AND UNDER  
8. CONTINUE BY FOLLOWING THE  
PATTERN ILLUSTRATED BELOW.

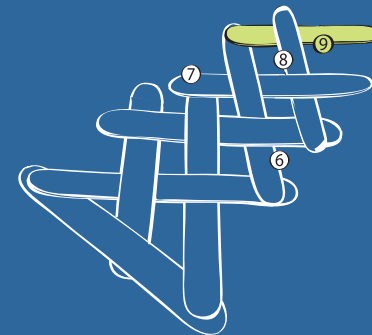



WHAT DO YOU CALL  
A BOOMERANG THAT  
DOESN'T WORK?

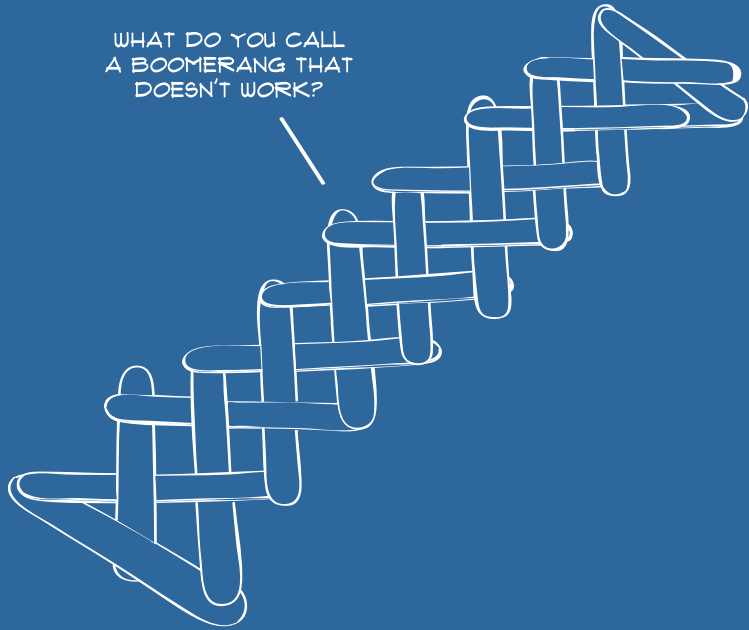

A STICK!

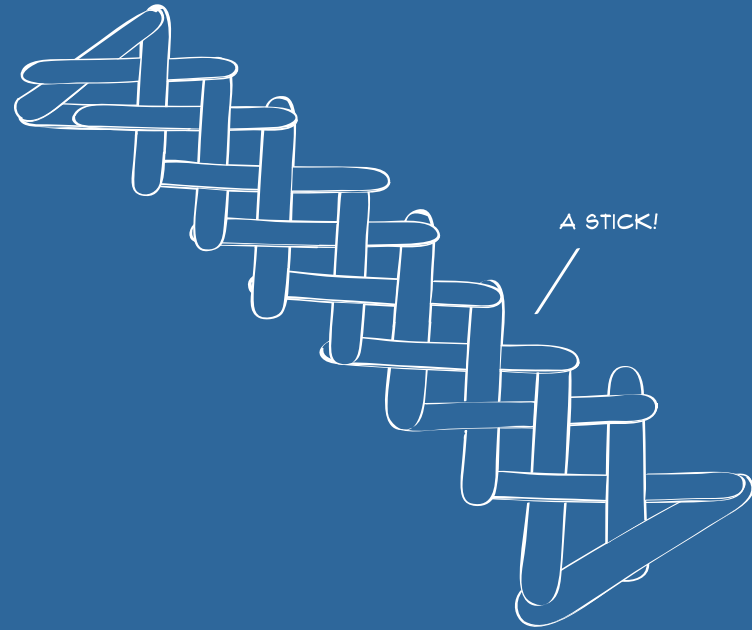

# THE ZIGZAG

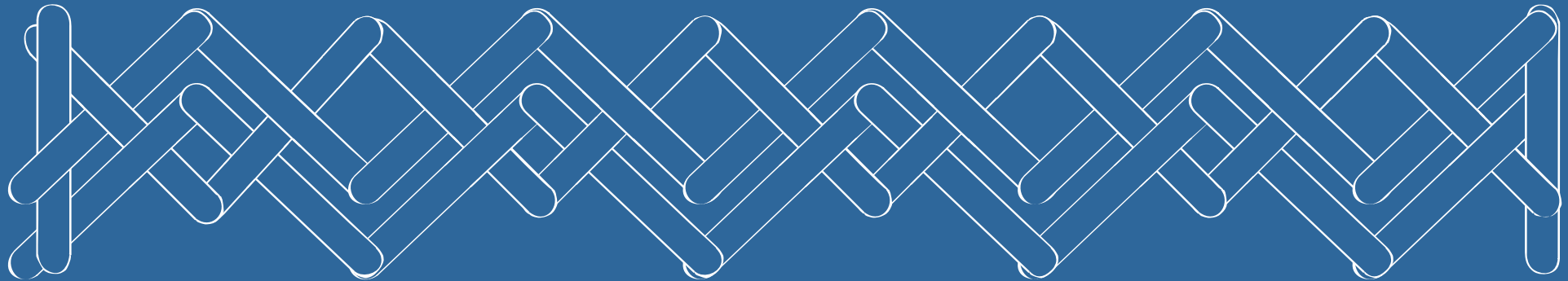

## STEP 1

LAY STICK 2 UNDER AND  
DIAGONAL FROM STICK 1.

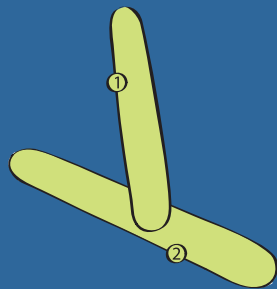

## STEP 2

LAY STICK 3 UNDER THE LEFT  
SIDE OF 2 AND OVER 1.

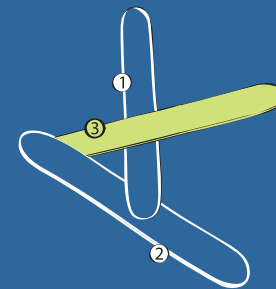

## STEP 3

WEAVE STICK 4 PARALLEL TO 1,  
UNDER 2, AND OVER 3.

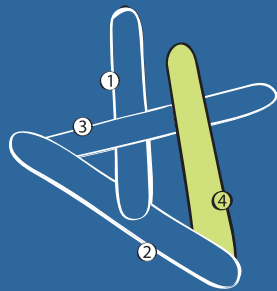

## STEP 4

LAY STICK 5 OVER 4 AND  
PARALLEL TO 3.

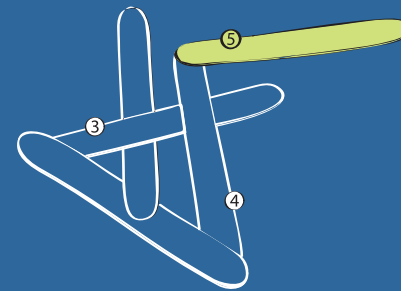

## STEP 5

LAY STICK 6 PARALLEL TO 5,  
UNDERNEATH 1.

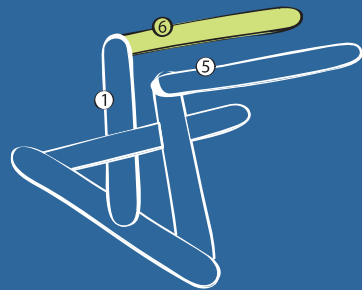

## STEP 6

LAY STICK 7 PARALLEL TO 1  
AND 4, WEAVING IT UNDER 3,  
OVER 5, AND UNDER 6.

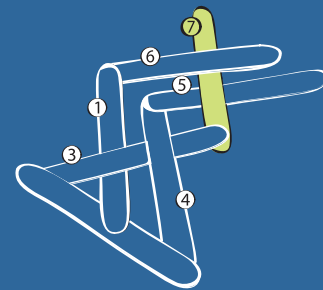

## STEP 7

LAY STICK 8 PARALLEL TO 6  
AND 5, UNDERNEATH 7.

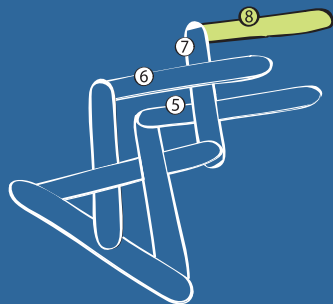

## STEP 8

LAY STICK 9 PARALLEL TO 7,  
WEAVING IT UNDER 5 AND OVER  
8. CONTINUE BY FOLLOWING THE  
PATTERN ILLUSTRATED BELOW.

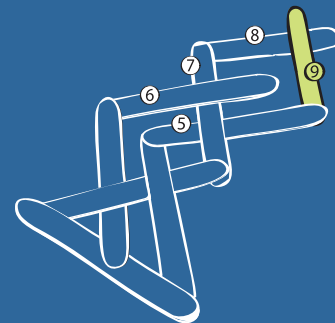

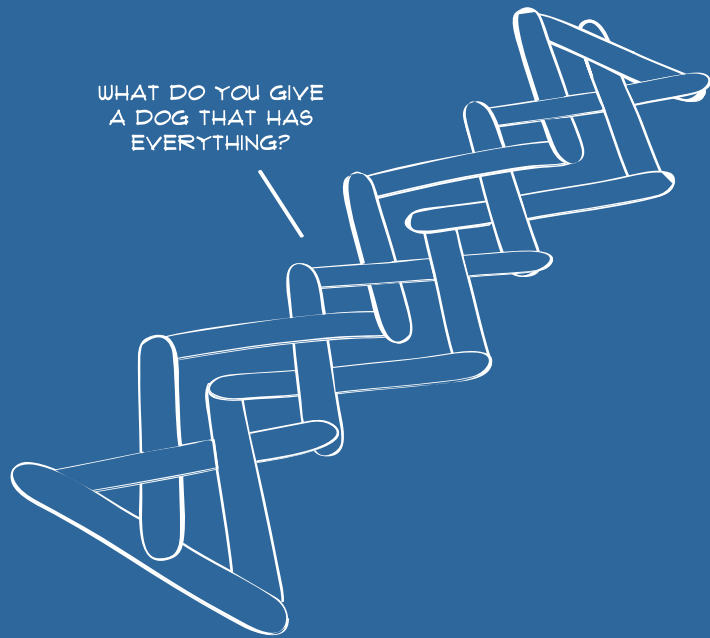

WHAT DO YOU GIVE  
A DOG THAT HAS  
EVERYTHING?

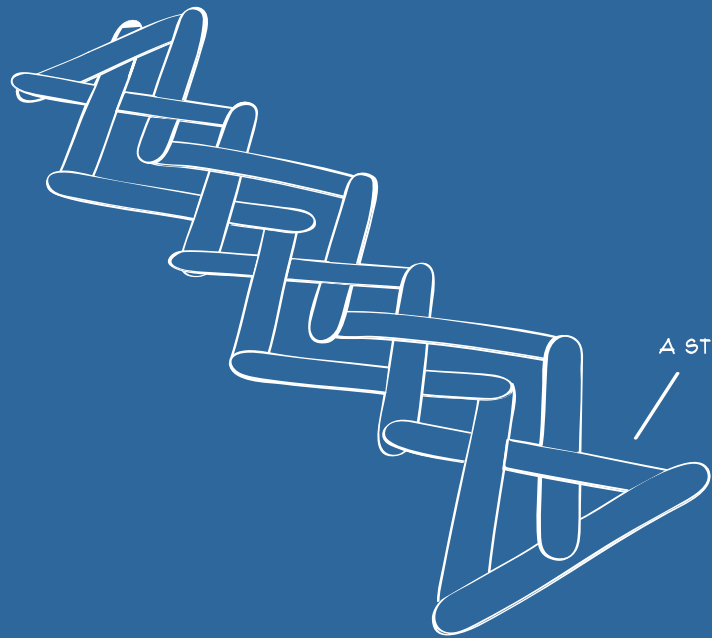

A STICK!

# DECOY

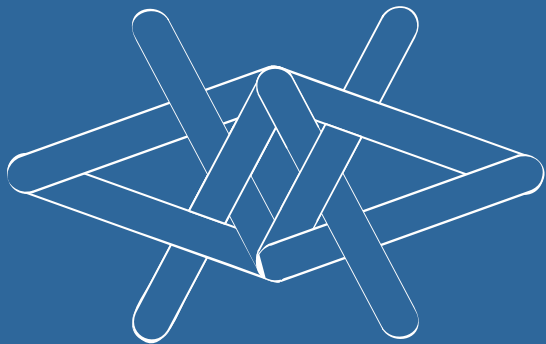

## STEP 1

PLACE YOUR FIRST STICK, THEN LAY STICK 2 OFF CENTER AND PERPENDICULAR TO 1. STACK STICK 3 ATOP 1 AND 2.

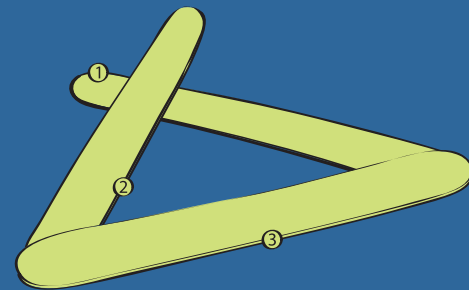

## STEP 2

WEAVE STICK 4 OVER 2, UNDER 1, AND OVER 3.

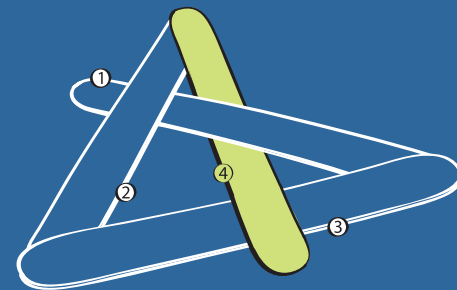

### STEP 3

SLIDE STICK 5 UNDERNEATH 2.

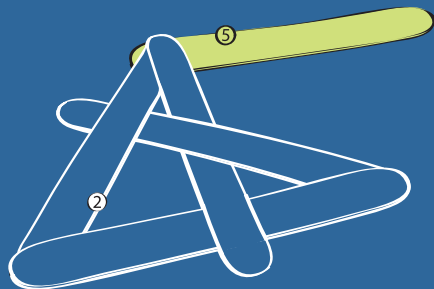

### STEP 4

LAY STICK 6 ON TOP OF STICKS 3 AND 5.

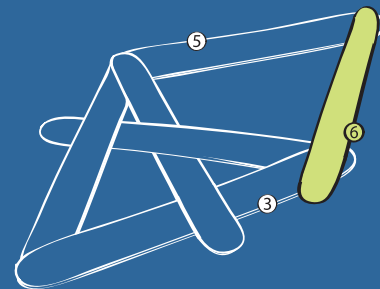

### STEP 5

WEAVE STICK 7 UNDER 5 AND 3, BUT OVER 1.

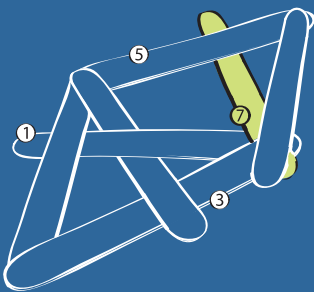

### STEP 6

WEAVE STICK 8 OVER 4, UNDER 7, AND OVER 6.  
NOW GO SET UP YOUR DECOY TO ATTRACT PESKY SIBLINGS OR OFFICE PERSONAL - MAKING THEM EASY ARTILLERY TARGETS!

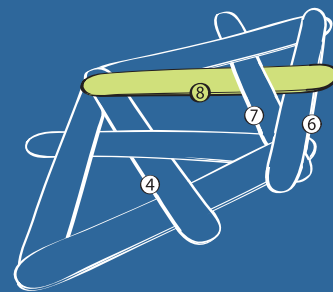

# SLINGSHOT

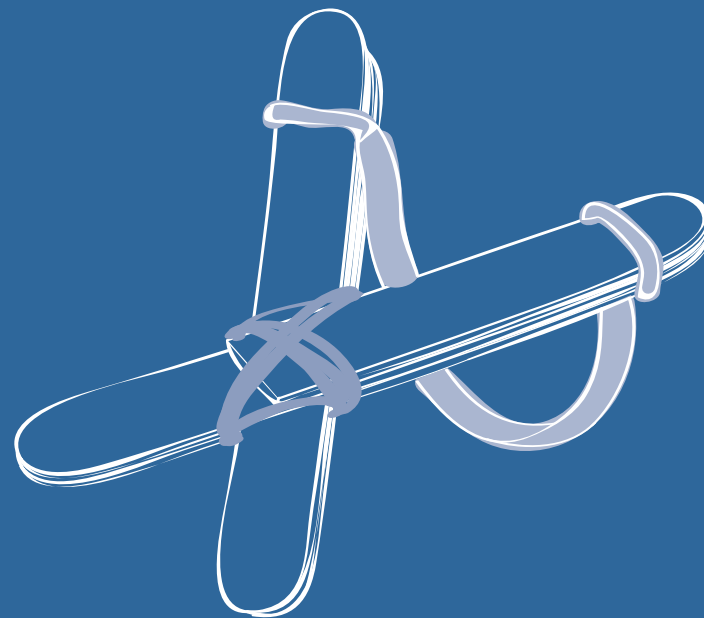



## STEP 1

LAY TWO TONGUE DEPRESSORS ON TOP OF ONE ANOTHER.

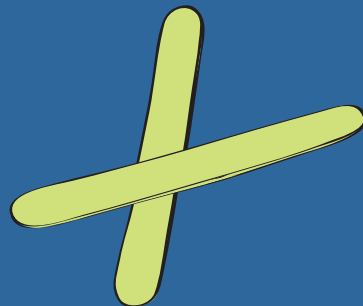

## STEP 2

REPEAT STEP 1, THEN ADD TWO MORE TONGUE DEPRESSORS CUT TO 3/4 THEIR ORIGINAL LENGTH - ONE TO THE TOP AND ONE TO THE BOTTOM.

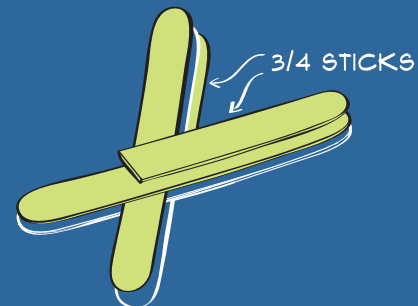

## STEP 3

WRAP STRING UP AND DOWN AND SIDE TO SIDE AROUND THE STICKS UNTIL EVERYTHING FEELS TIGHTLY WOUND.

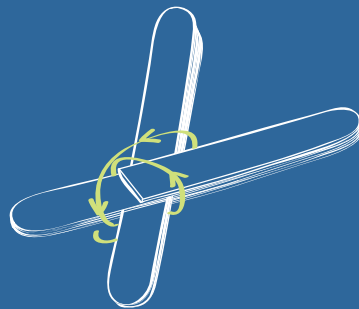

## STEP 4

CUT A RUBBER BAND AND TIE EACH SIDE TO YOUR SLINGSHOT. NOW GO SCAVENGE FOR SOMETHING TO SHOOT! YOU'RE DONE!

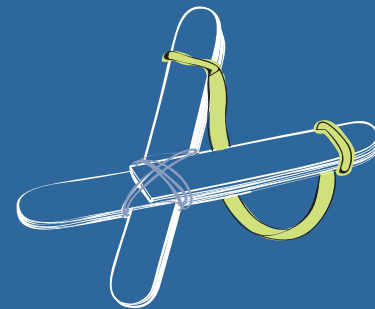

# CATAPULT

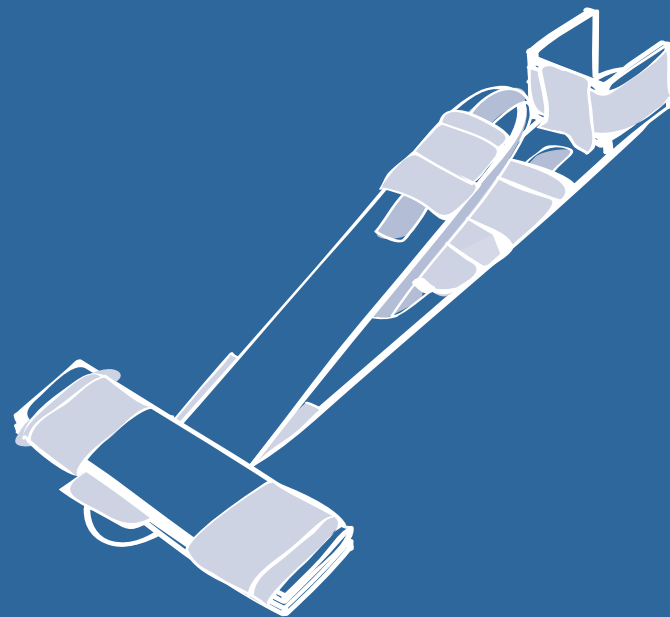

## STEP 1

TIP: WRAP THE TAILS  
IN TAPE SO THAT ALL  
THE STICKY SIDES  
ARE COVERED.

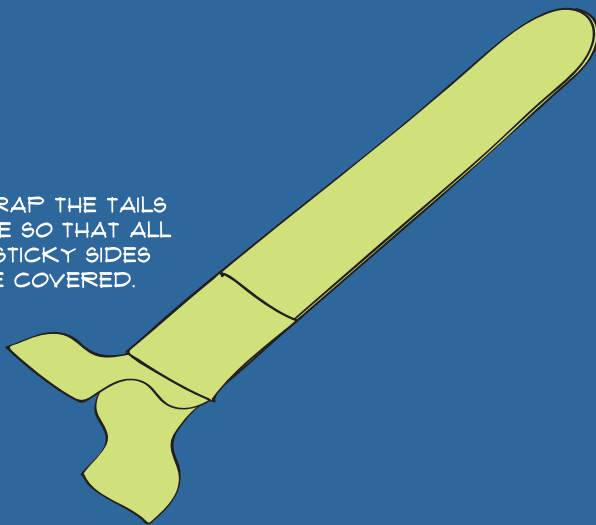

TO START, CREATE TWO TAILS ON THE TOP AND BOTTOM OF A  
TONGUE DEPRESSOR USING 3-4 PIECES OF MASKING TAPE.

## STEP 2

TIP: TAPE  
ROUGHLY 1" FROM  
THE END OF YOUR  
NEW STICK.

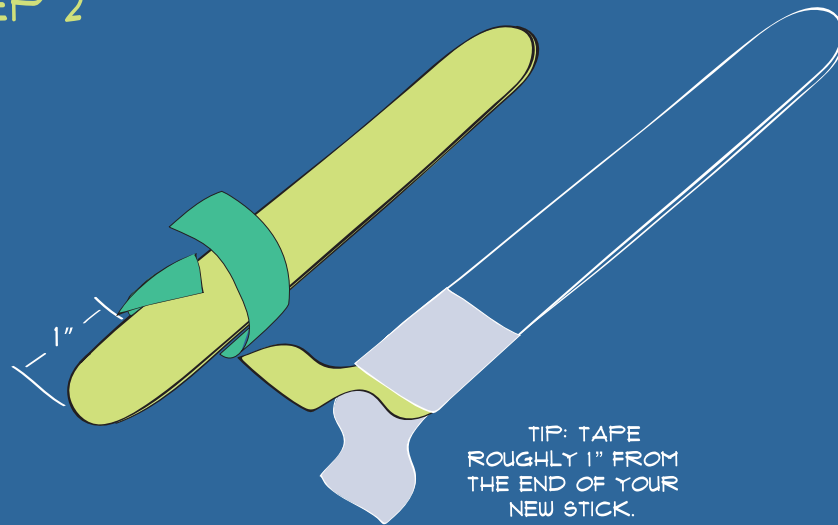

TAPE THE TOP TAPE TAIL YOU CREATED TO A NEW TONGUE  
DEPRESSOR.

### STEP 3

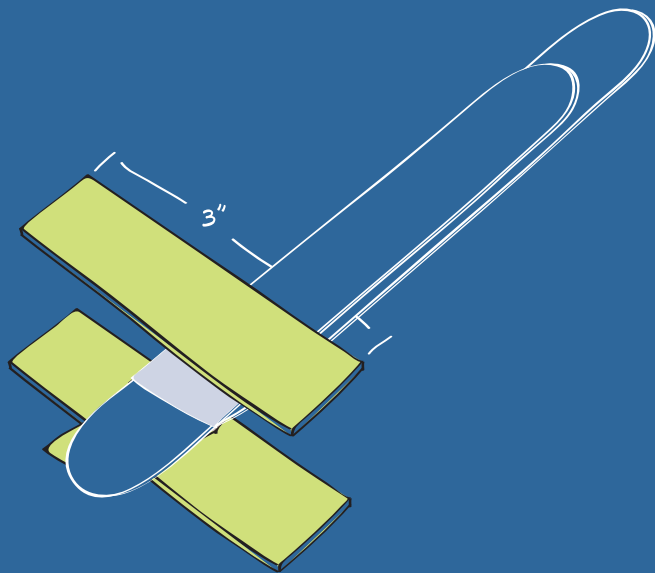

SANDWICH THE END OF YOUR NEW TONGUE DEPRESSOR AND THE BOTTOM TAPE TAIL IN BETWEEN TWO 3" TONGUE DEPRESSOR PIECES.

### STEP 4

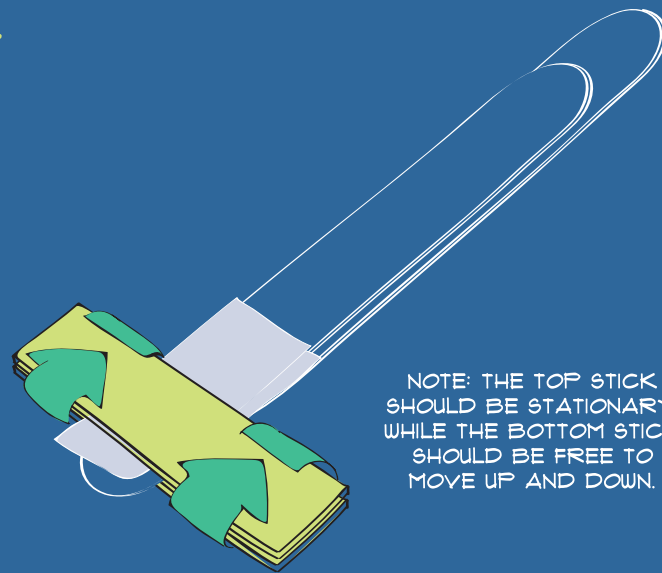

NOTE: THE TOP STICK SHOULD BE STATIONARY, WHILE THE BOTTOM STICK SHOULD BE FREE TO MOVE UP AND DOWN.

TAPE AROUND THE 3" STICK PIECES VERY TIGHTLY.

## STEP 5

NOTE: FOR A SHORTER  
BUCKET OPTION, USE 1"  
POPSICLE PIECES

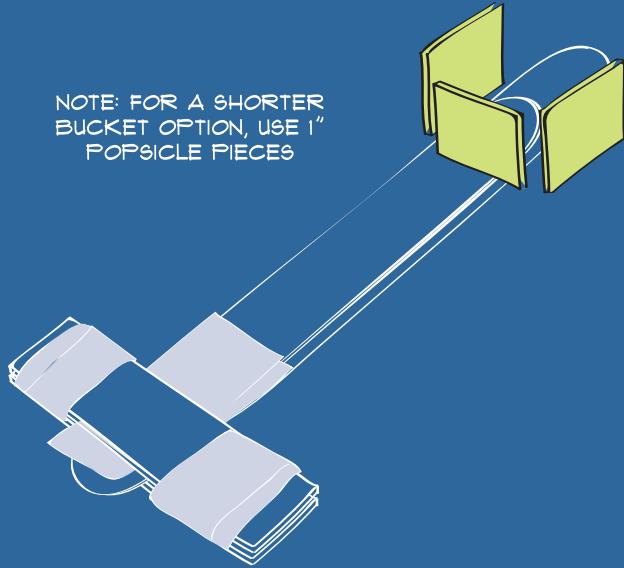

MAKE A BUCKET FOR YOUR CATAPULT USING THREE 1" TONGUE  
DEPRESSOR PIECES.

## STEP 6

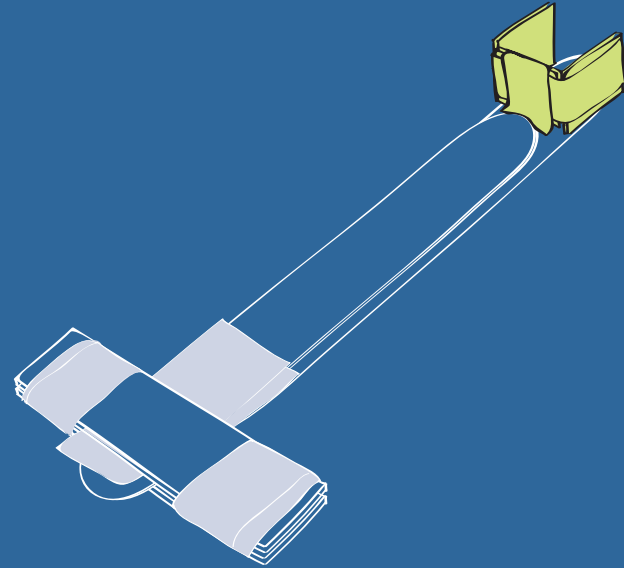

ATTACH ALL THE 1" STICK PIECES BY TAPING EACH OF THE SIDES  
TOGETHER, THEN TAPE EVERYTHING TO THE TOP STICK.

## STEP 7

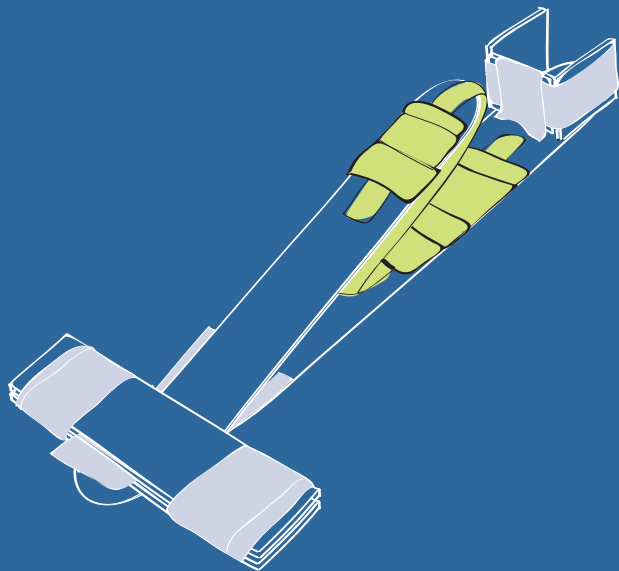

TAPE A RUBBER BAND TO THE FRONT OF THE TOP STICK AND THE FRONT OF THE BOTTOM STICK.

## STEP 8

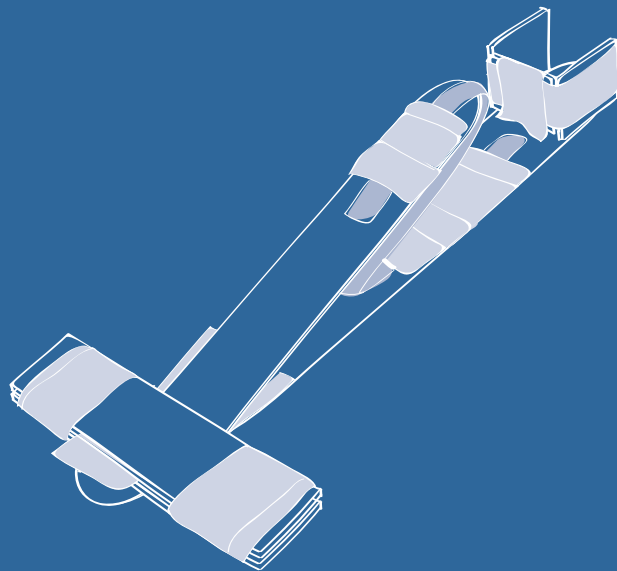

GET READY TO FLICK! YOU'VE GOT A HANDHELD CATAPULT!



USING ONE HAND, WRAP FINGERS  
AROUND THE BOTTOM POST



USING THE OTHER HAND, PULL BACK  
A LOADED ARM, AIM, AND **FIRE!**

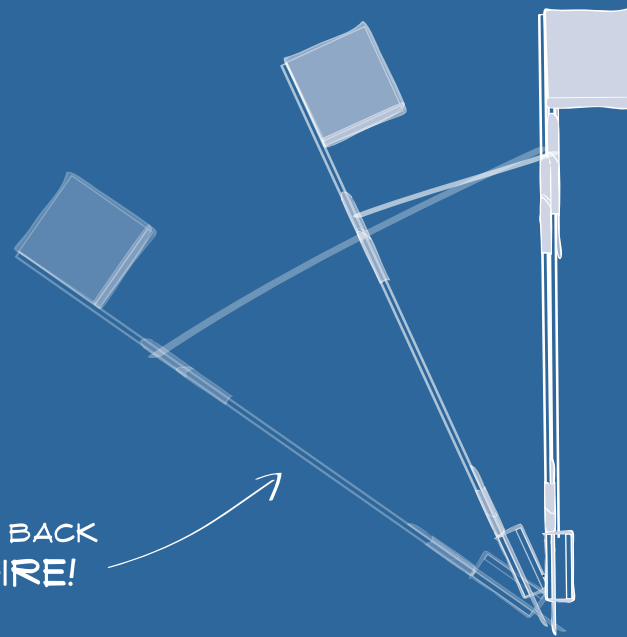
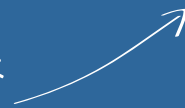

# BALLISTA

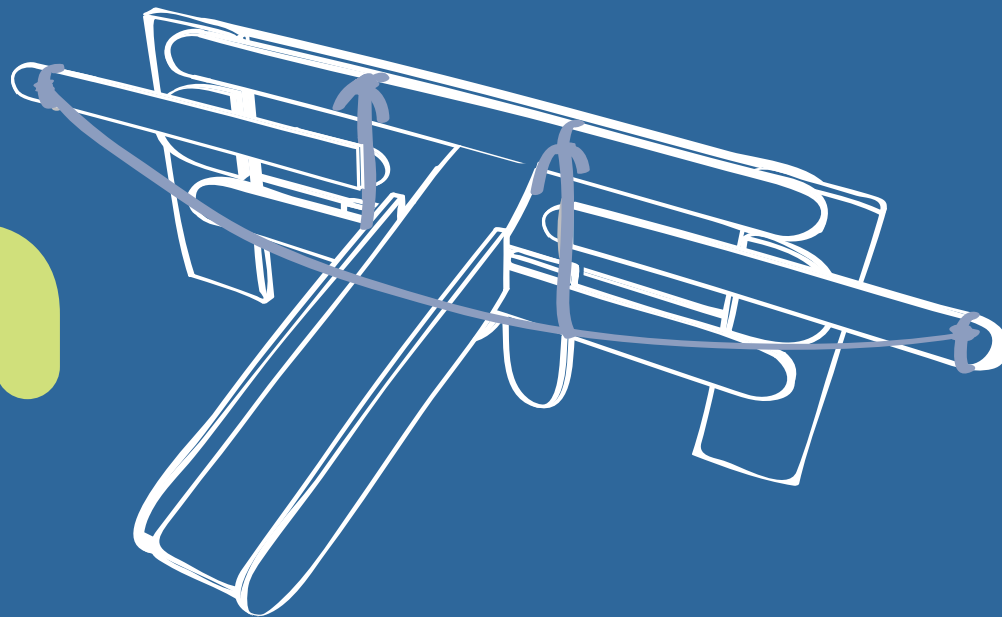



## STEP 1

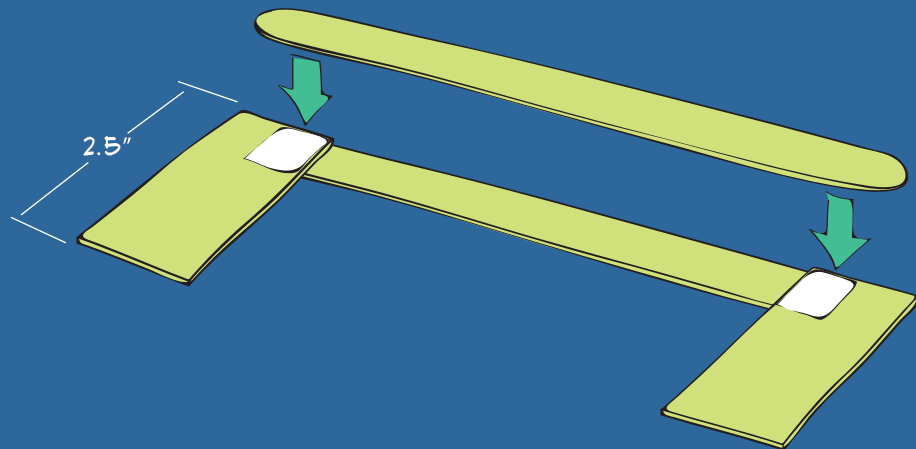

TO START, CUT TWO TONGUE DEPRESSORS DOWN TO 2.5". APPLY GLUE TO THE TOP AND BOTTOM CORNERS OF EACH PIECE, THEN APPLY POPSICLE STICKS TO GLUED AREA ON BOTH SIDES.

## STEP 2

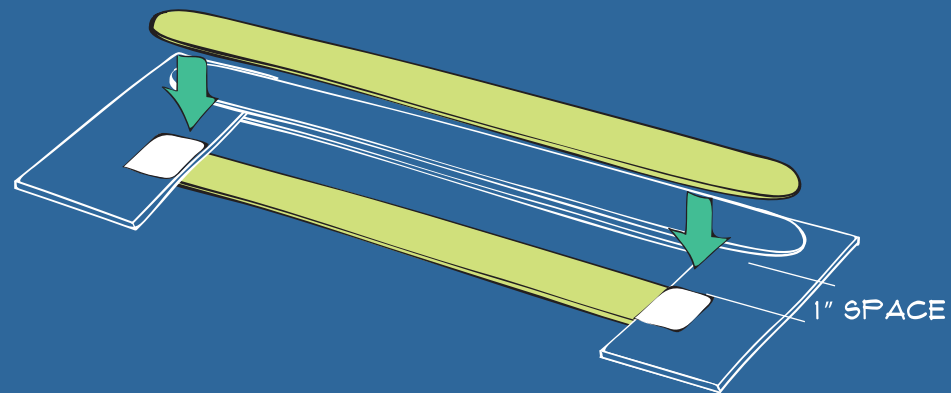

GLUE TWO MORE POPSICLE STICKS TO YOUR 2.5" STICK PIECES ROUGHLY 1" BELOW THE FIRST SET.

### STEP 3

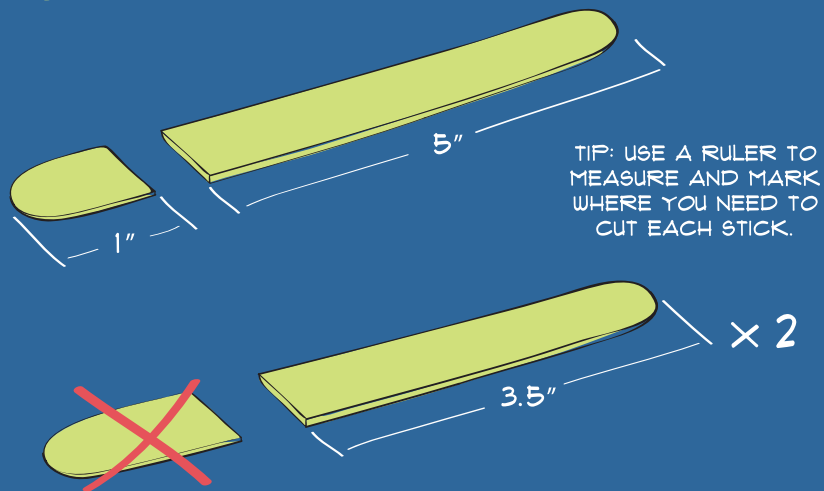

CUT ONE TONGUE DEPRESSOR INTO A 1" PIECE AND A 5" PIECE.  
CUT TWO MORE TONGUE DEPRESSORS INTO 3.5" PIECES.  
SAVE ONLY THE INDICATED PIECES.

### STEP 4

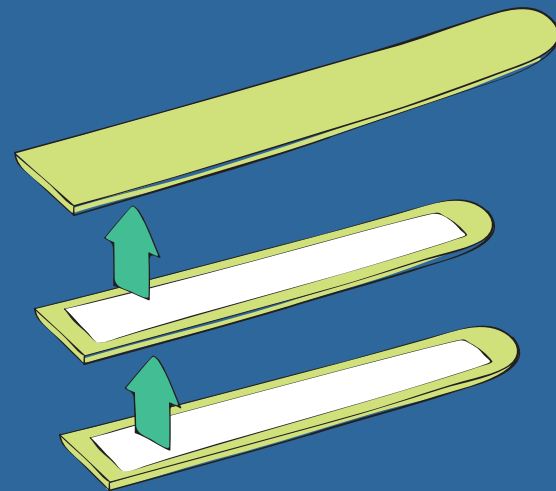

ALIGN THE STRAIGHT ENDS OF YOUR 5" AND TWO 3.5" PIECES.  
GLUE ALL THE STICKS TOGETHER. THIS WILL BE YOUR PLANK.

## STEP 5

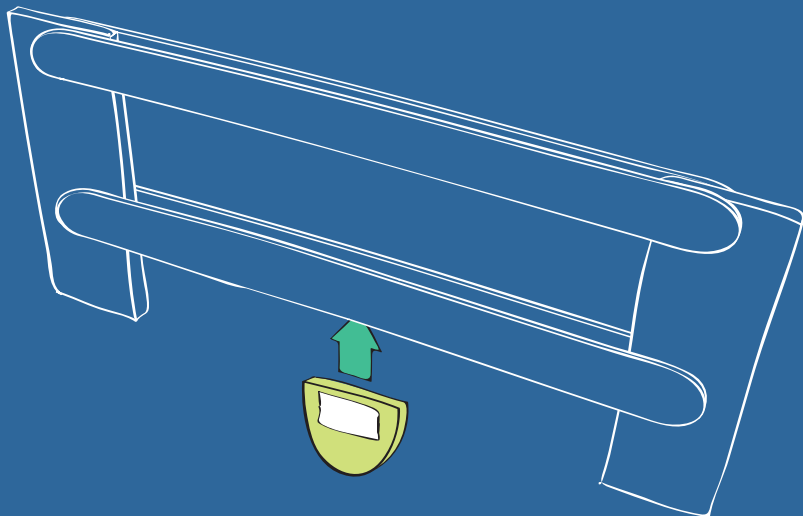

TAKE THE 1" PIECE YOU CUT TWO STEPS AGO, ADD GLUE TO EACH SIDE, THEN SLIDE IT IN BETWEEN THE MIDDLE OF THE TWO LOWER SUPPORT STICKS.

## STEP 6

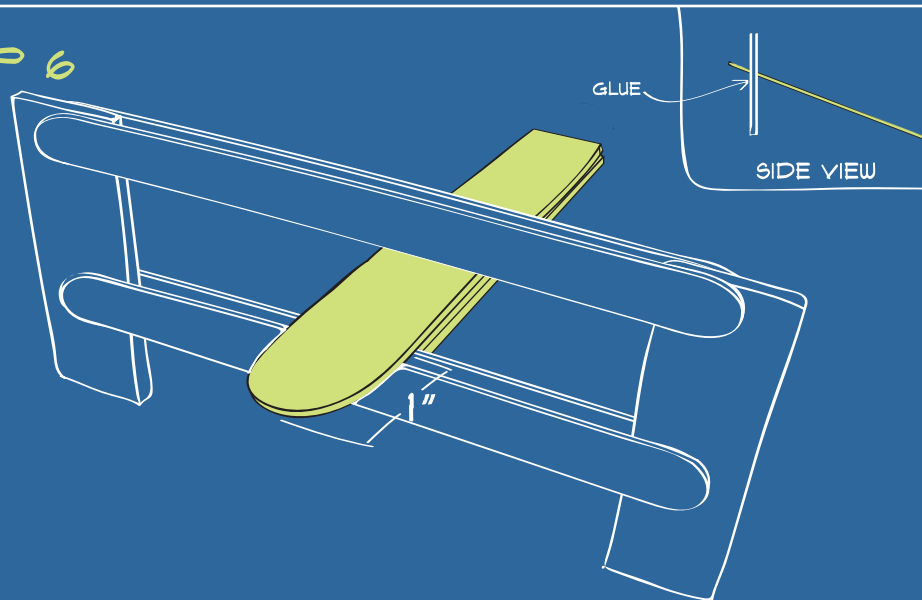

WITH THE 5" STICK ON TOP, SET YOUR PLANK ROUGHLY 1" OUT THROUGH THE SUPPORTS YOU CREATED EARLIER, THEN GLUE THIS PIECE TO THE LOWER SUPPORT STICKS.

## STEP 7

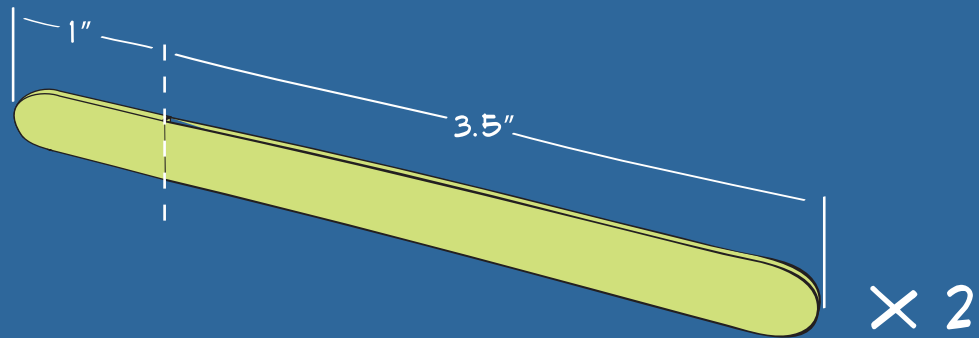

CUT TWO POPSICLE STICKS INTO 1" AND 3.5" PIECES.

## STEP 8

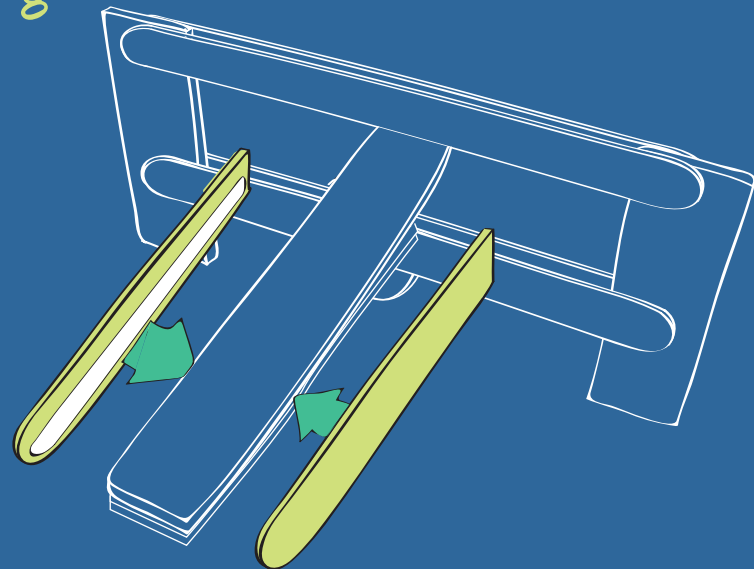

TURN YOUR BALLISTA AROUND 180 DEGREES. GLUE THE TWO 3.5" PIECES TO SIDES OF YOUR PLANK TO MAKE A RAIL.

## STEP 9

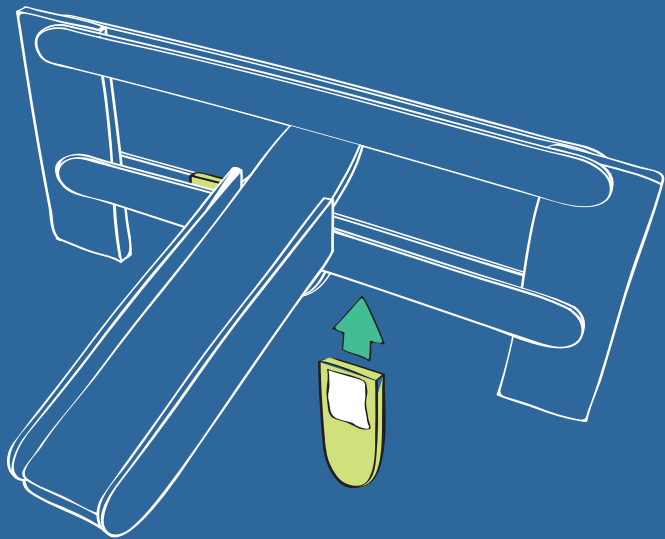

USE THE 1" PIECES AS LEGS BY GLUING THEM IN BETWEEN YOUR LOWER SUPPORT STICKS ON EITHER SIDE OF YOUR PLANK.

## STEP 10

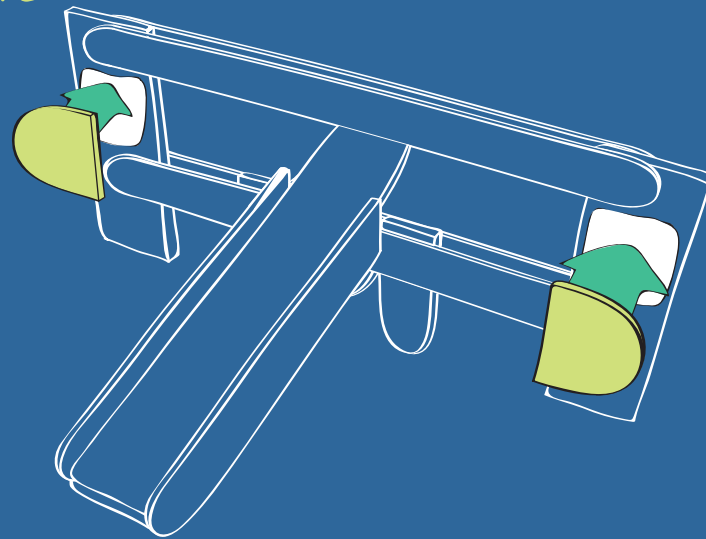

CUT THE ENDS OFF TWO TONGUE DEPRESSORS AND GLUE THOSE PIECES IN BETWEEN YOUR TWO SETS OF SUPPORTS.

## STEP 11

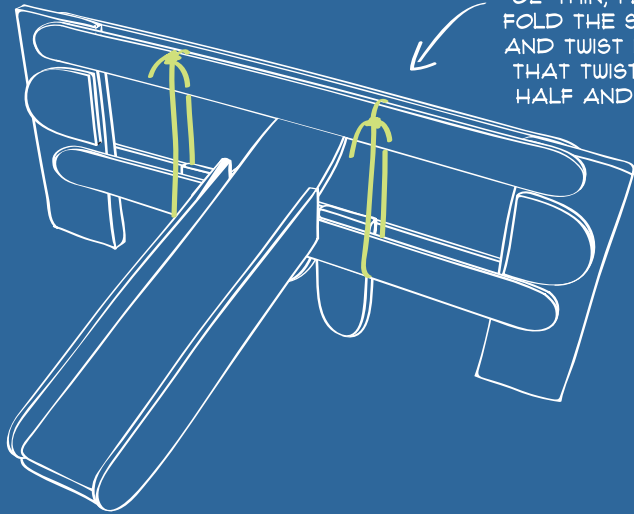

TIP: BEFORE TYING ON ANY OL' THIN, FLIMSY STRING, FOLD THE STRING IN HALF AND TWIST IT. THEN FOLD THAT TWISTED STRING IN HALF AND TWIST AGAIN.

TIGHTLY TIE TWO STRINGS IN BETWEEN YOUR SUPPORTS, ONE ON EACH SIDE OF YOUR PLANK. IF NECESSARY, USE ANOTHER STICK TO WEDGE THE STRING IN BETWEEN THE SUPPORT STICKS.

## STEP 12

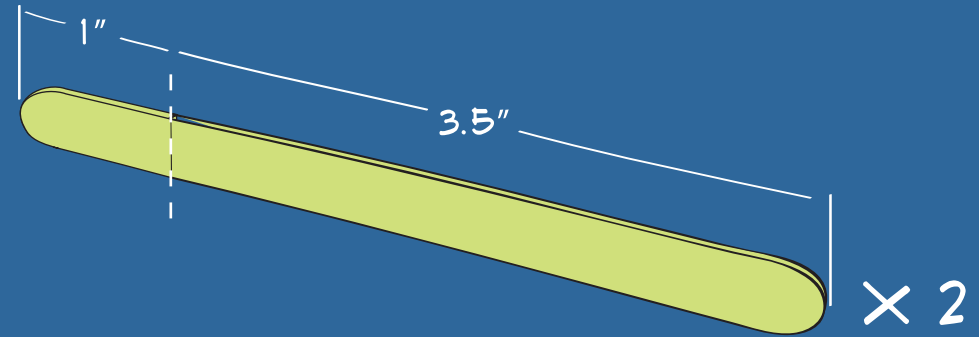

CUT TWO POPSICLE STICKS INTO 1" AND 3.5" PIECES.

## STEP 13

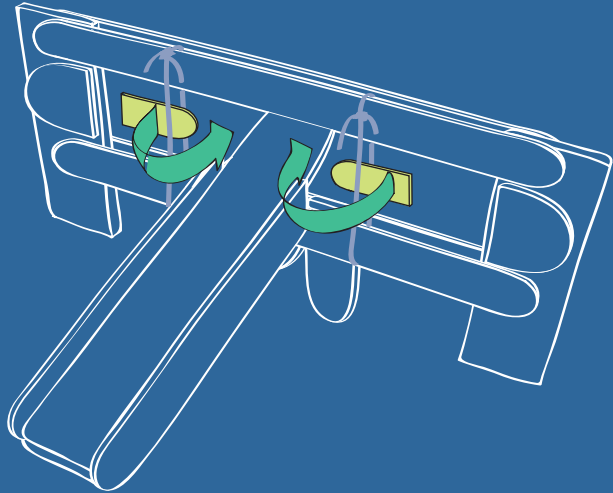

PLACE THE 1" STICKS INSIDE OF YOUR STRING LOOPS AND TWIST THEM AROUND UNTIL THE STRINGS ARE TIGHT (ONE OR TWO TURNS SHOULD WORK) - THIS GIVES YOUR BALLISTA LAUNCHING POWER!

## STEP 14

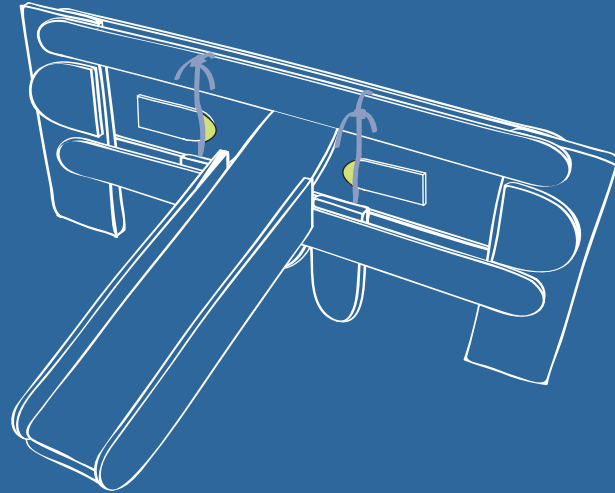

EXPOSE ONLY A SMALL PORTION OF THE END OF YOUR 1" STICKS.

## STEP 15

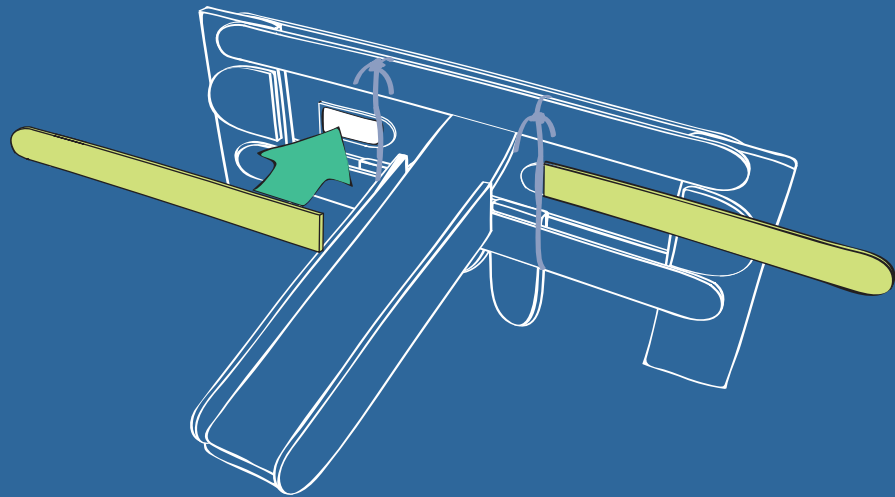

GLUE YOUR 3.5" STICKS TO THE NON-EXPOSED BACK OF YOUR 1" STICKS. MAKE SURE THESE ARMS SIT BEHIND THE FRAME.

## STEP 16

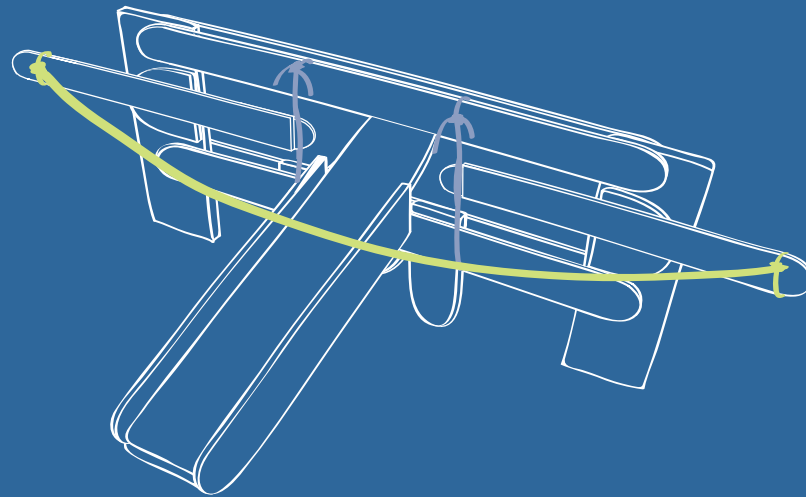

FINISH YOUR BALLISTA WITH A THIN STRING OR RUBBER BAND THAT CONNECTS BOTH ARMS. MAKE SURE EVERYTHING IS TIGHT SO YOU GET A SNAPPY LAUNCH!



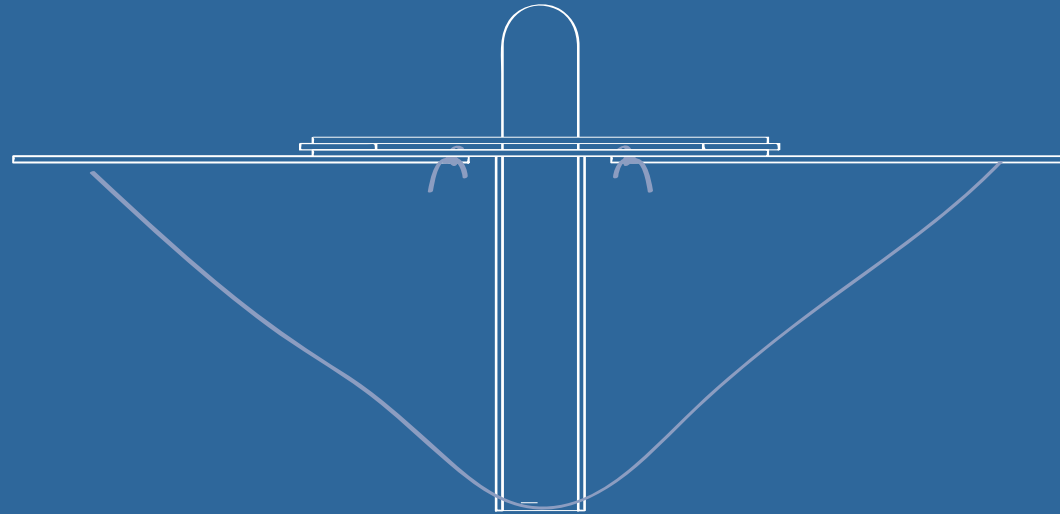

LOAD UP YOUR PLANK, PULL STRING, AND FIRE! REALLY GO BALLISTA!

# STILL WANT MORE? TRY MAKING THESE STICK GRENADES!

A-BOMB:



THROWING STAR:

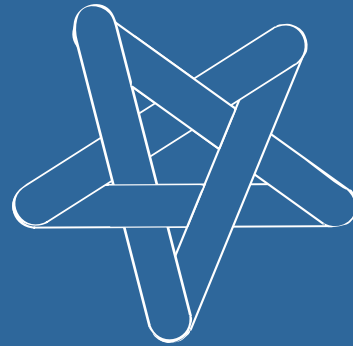

ARROW:

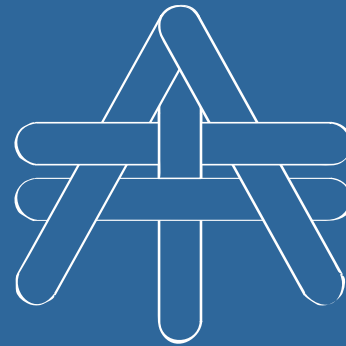

TRIQUETRA:

